

20.5" Recessed Motor & Lighting Truss v2

Designed for use as a medium duty "Mother Grid" type truss system. The 30" width of the truss permits chain motors and lights to be mounted and travelled inside the truss.

- Saves manpower in handling all the separate pieces of equipment.
- Saves time in assembly.
- Saves truck space.

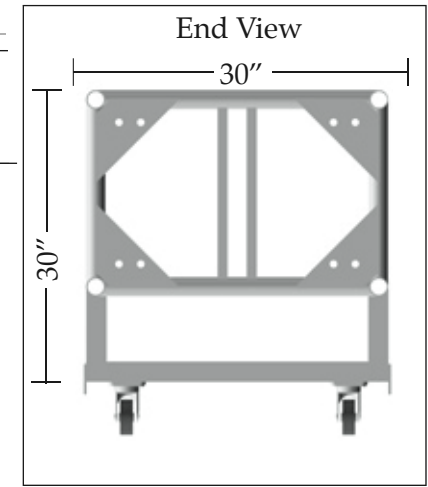
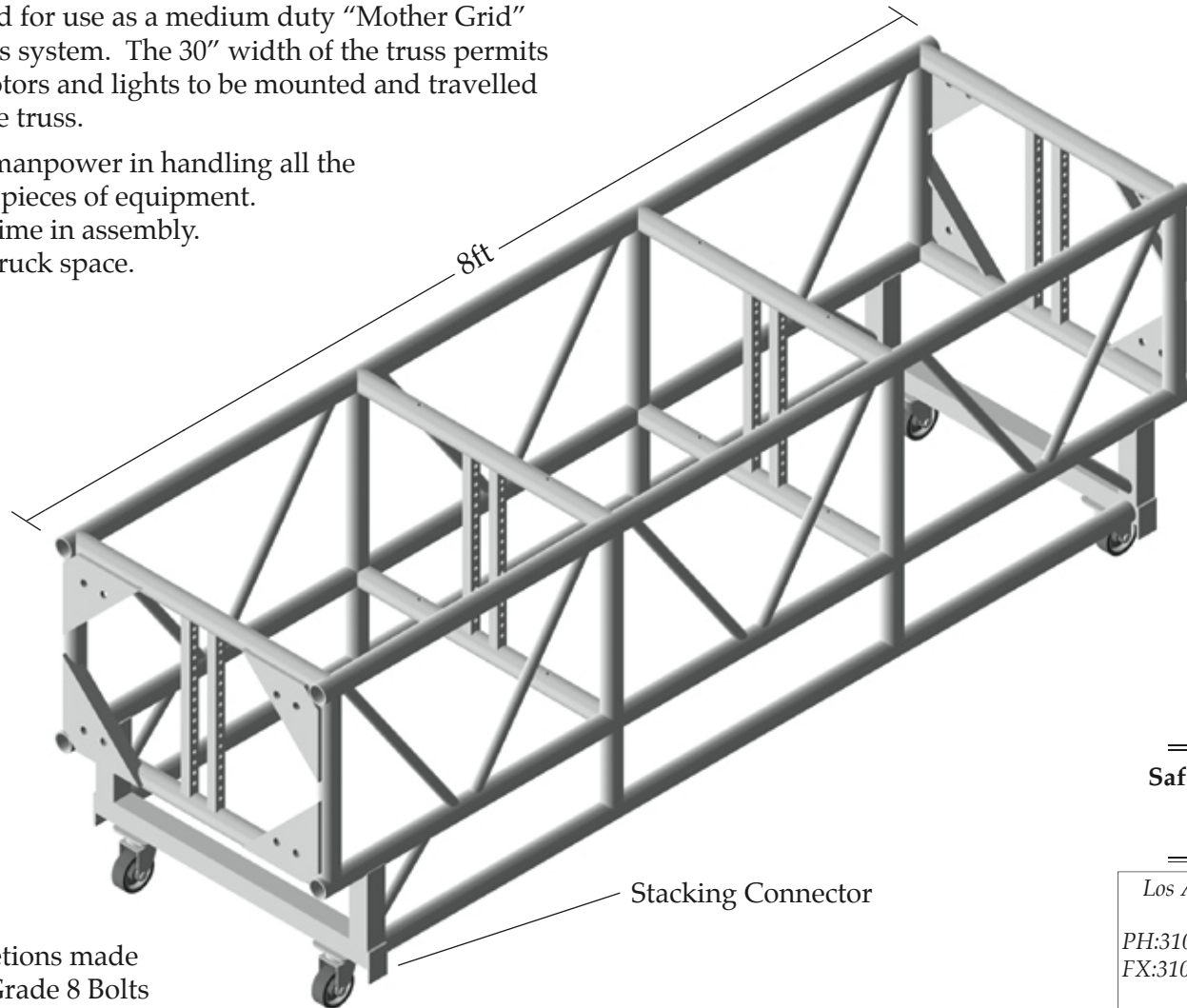

Available In:	Weights:
4ft 9in Section	68 lbs
5ft Section	
8ft Section	94 lbs
4 Way Corner	61 lbs

Safe Working Load:
2,000 lbs with Speeds up to 40ft/min

Connections made
5/8" Grade 8 Bolts

Stacking Connector

Los Angeles

PH:310.538.4175
FX:310.538.4180

15823 S. Main Street
Los Angeles, CA 90248



www.sgsp.net

Las Vegas

PH:702.270.4240
FX:702.270.4221

6585 Escondido St., STE G
Las Vegas, NV 89119