

Multi-Directional Personnel Flying System

A Trolley with Rotating "Yo-Yo" Style Cable Lift System

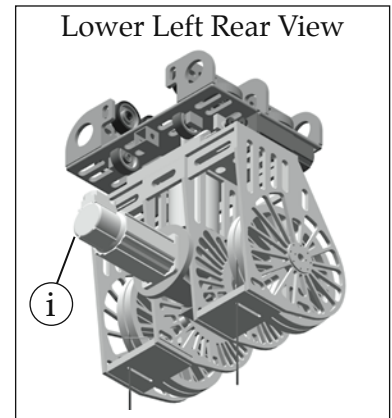
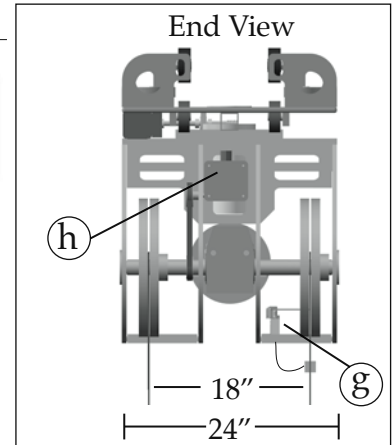
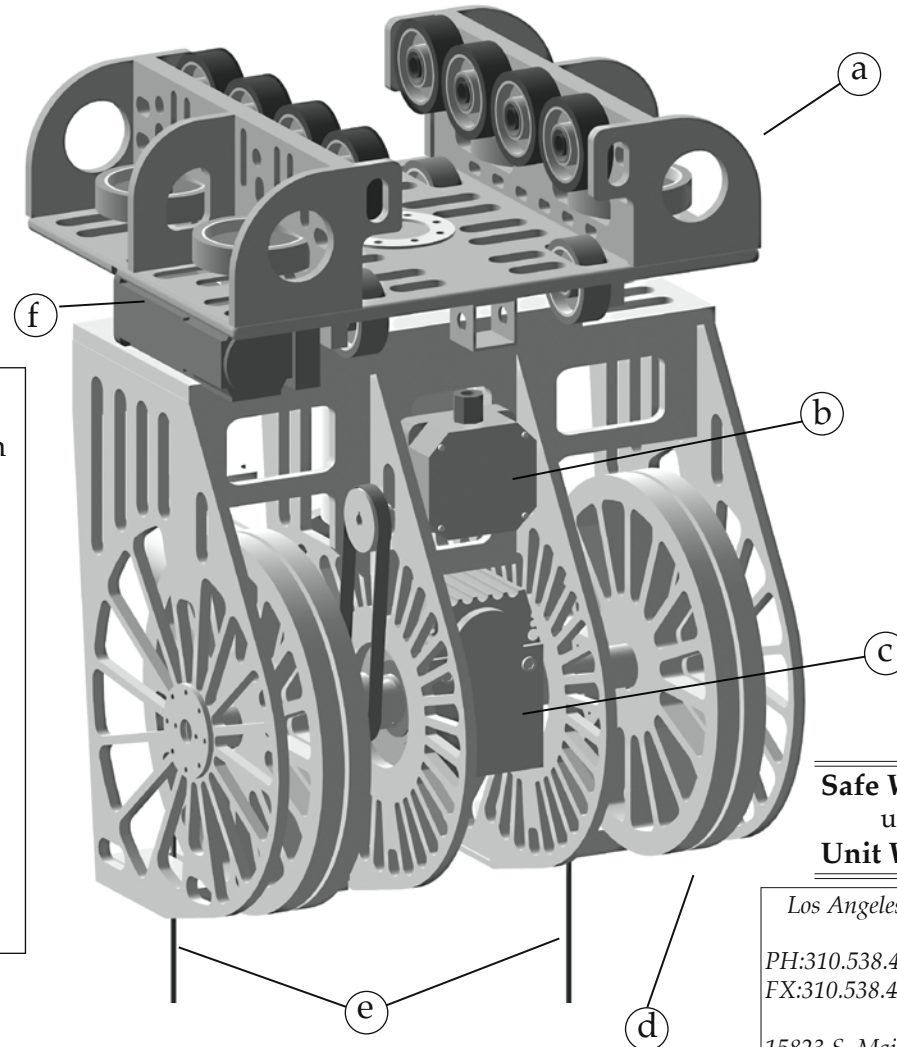

- a) Manual "F" Type Trolley
- b) Rotary Up & Down Safety Limit Switch
- c) Standard Gearbox - Ratio 94.35:1
(High Speed Gearbox - Ratio 37.91:1)
- d) Pinch Wheels
- e) 3/16" - 7x19 Cable
- 4,200lbs min breaking strain
- f) Rotational Motor
- g) Back-up Floating Type Limit
Safety Switch
- h) Electrical Commutator
- i) Yo-Yo Servo Motor - MKD41

Safe Working Load: 300 lbs with Speeds
up to ft/min
Unit Weight: lbs

Part of the
SGPS SERVO COMPONENT SYSTEM

Los Angeles

PH:310.538.4175
FX:310.538.4180

15823 S. Main Street
Los Angeles, CA 90248



Las Vegas

PH:702.270.4240
FX:702.270.4221

6585 Escondido St., STE G
Las Vegas, NV 89119