

Static Medium Duty "Yo-Yo"

Designed to give safe, precise positioning, variable speed, & up and down movement of people, scenery cameras, and low resolution LED's etc.

- Can be flown independently.
- Bolts directly to standard 20.5 Box Truss
- Shown with optional Spreader Bar to reduce to a single lift point

- a) Motor Safety Brake
 b) Worm Type Gear Box - cannot back turn to gearbox (acts as Secondary Safety Brake)
 c) Spreader Bar
 d) Rotary Limit Switch
 e) Lift Point
 f) Float Type Limit Switch - this is a Second Safety Back-up to the Rotary Limit Switch.

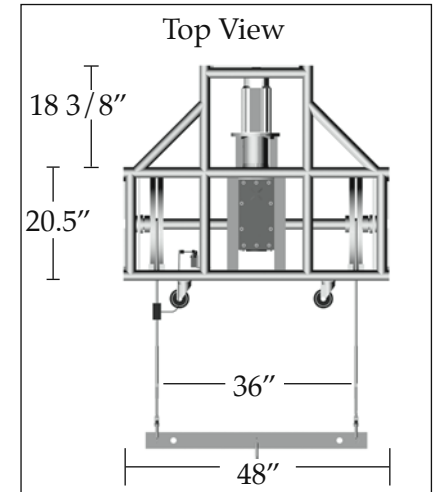
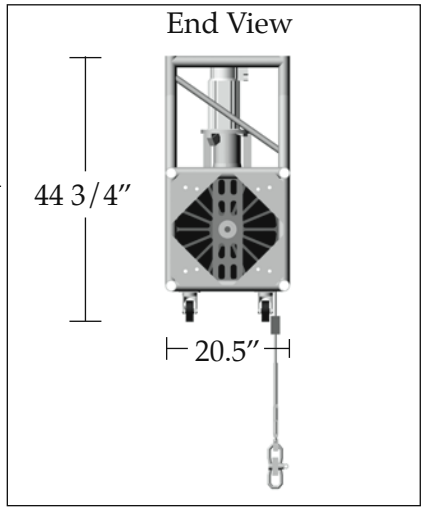
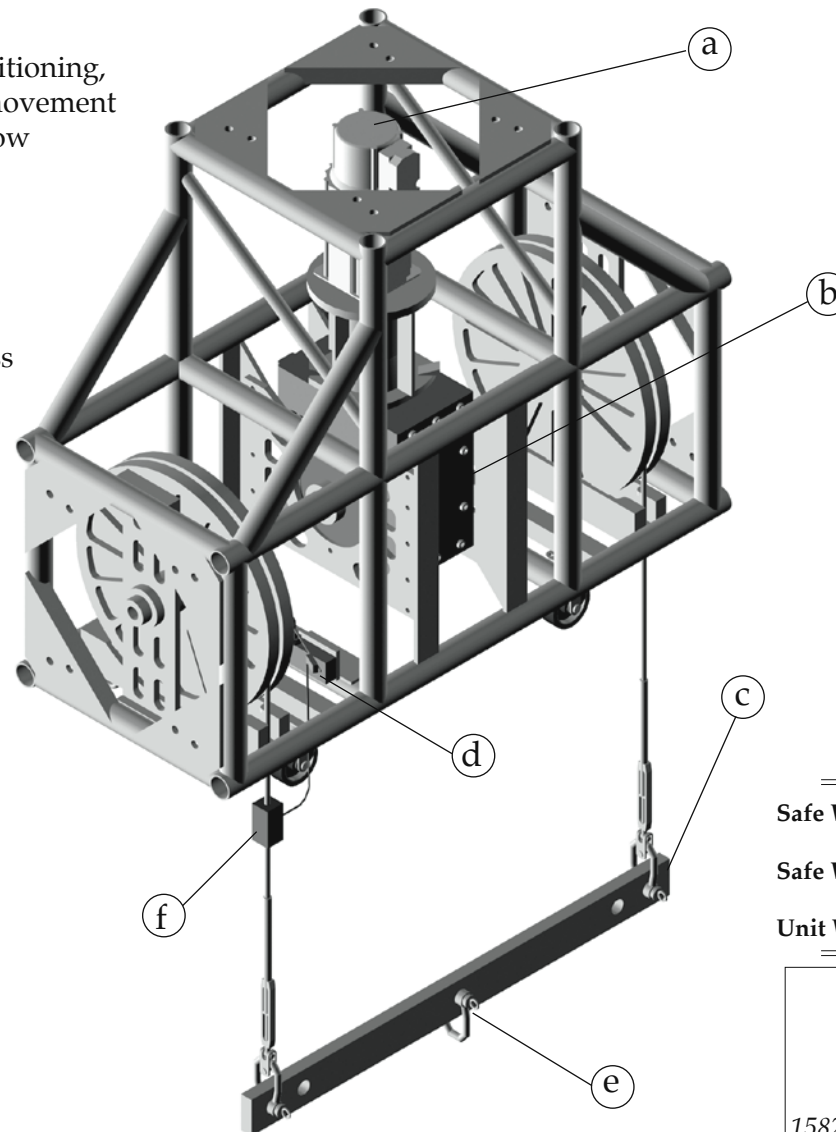

Safe Working Load: Single Reeved- 800 lbs with Speeds up to 90ft/min
Safe Working Load: Double Reeved- 1,600lbs with Speeds up to 45ft/min
Unit Weight: 435 lbs

 15823 S. Main Street • Los Angeles, CA 90248
 PH:310.538.4175 • www.sgps.net • FX:310.538.4180

Part of the
 SGPS SERVO COMPONENT SYSTEM