

# Static "Yo-Yo" Personnel Flying Machine

## A Compact "Yo-Yo" Unit

This system is designed to provide up to 50ft of safe variable speed and accurate positioning vertical lift for a person, camera, or other light weight equipment.

- Clamps directly on top of either 20.5" or 12" Box Truss.
- Can be independently flown.
- Can be bolted to the floor.

- a) Flying Attachment Points
- b) Worm Type Gear Box - cannot back turn the gearbox (acts as a secondary Safety Brake)
  - Standard Gearbox Ratio 94.35:1
  - High Speed Gearbox Ratio 37.91:1
- c) Pinch Wheel
- d) Alternative Direction Cable Guide
- e) Motor Safety Brake
- f) Rotary Limit Switch
- g) 3/16" - 7 x 19 Cable - 4,200lbs min breaking strain
- h) Float Type Limit Switch - acts as Secondary Safety Backup for Rotary Limit Switch

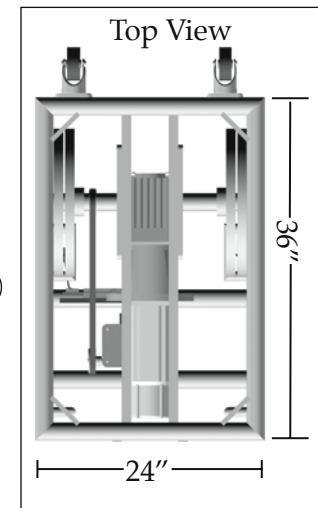
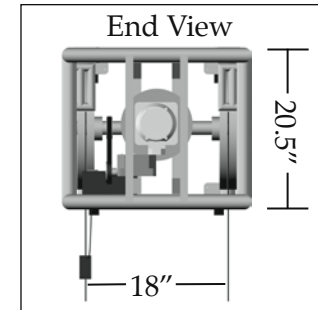
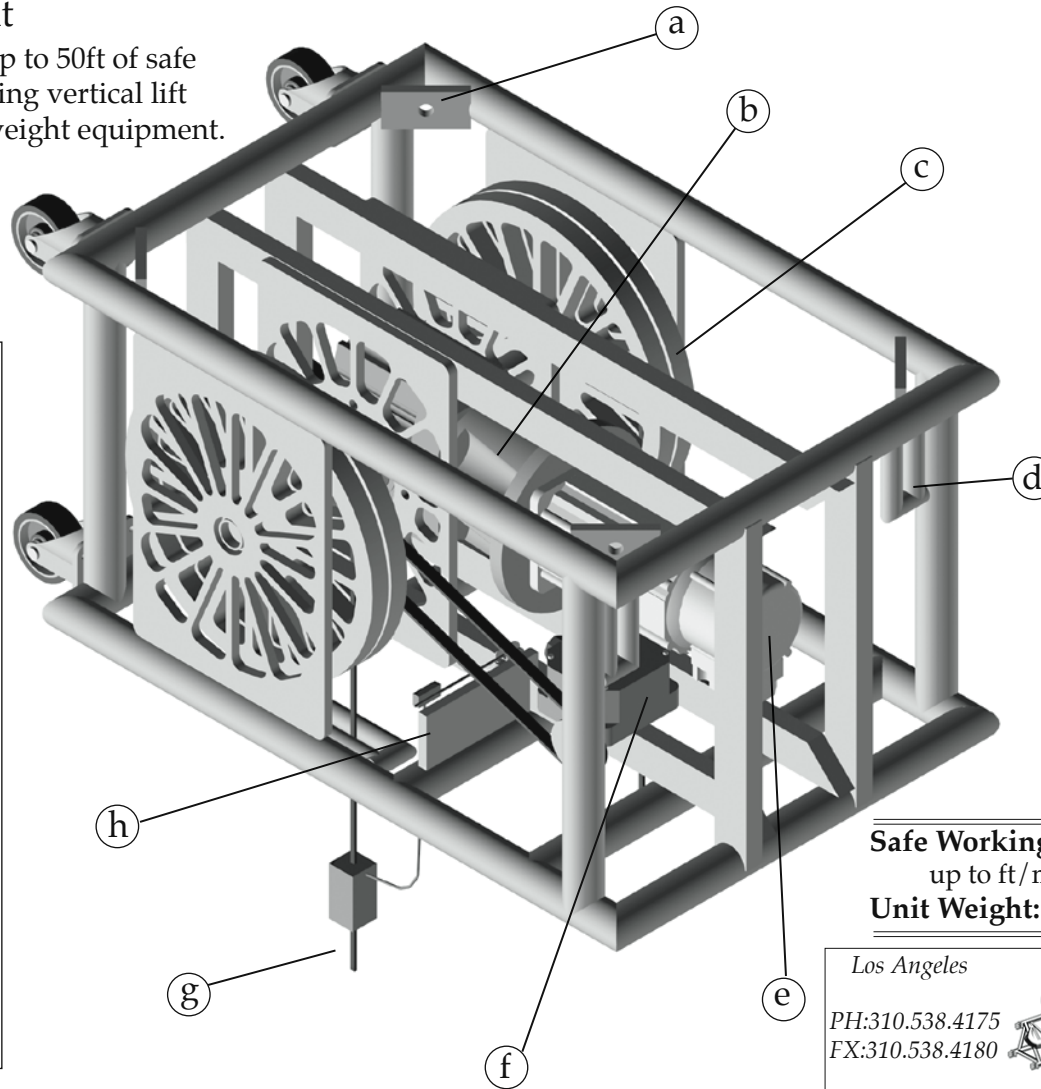

**Safe Working Load:** 300 lbs with Speeds up to ft/min  
**Unit Weight:** lbs

Part of the  
 SGPS SERVO COMPONENT SYSTEM

Los Angeles

PH:310.538.4175  
 FX:310.538.4180



www.sgsp.net

15823 S. Main Street  
 Los Angeles, CA 90248

Las Vegas

PH:702.270.4240  
 FX:702.270.4221

6585 Escondido St., STE G  
 Las Vegas, NV 89119